

Sylocraft®

Vibration Isolation - Perfectly Shaped



» Reduced noise and vibration transmission

» Time and costs savings due to custom-engineered design process

» Increased comfort for end users

getzner
engineering a quiet future

Shaping Technology

Getzner Sylocraft® offers the advanced vibration isolation performance to minimize primary and secondary noise in custom product design of small and complex geometries. It is composed in three standard foam grades with varying load bearing capacity obtained through innovative injection-moulding technology.

Depending on the foaming grade, Sylocraft® shows different stiffness properties for different needs and load ranges. It is used in all applications where an advanced vibration isolation in small parts with complex geometry is necessary. In addition, the customer specific environment and the desired long-term performance are part of the specification.

Mass applied for 5% compression

	Pad (100×100×20 mm)	Grommet (H = 25 mm, ø = 25 mm)
Sylocraft® SCA 5001	330 kg	10 kg
Sylocraft® SCA 7001	610 kg	15 kg
Sylocraft® SCA 8501	1160 kg	25 kg

Product Portfolio

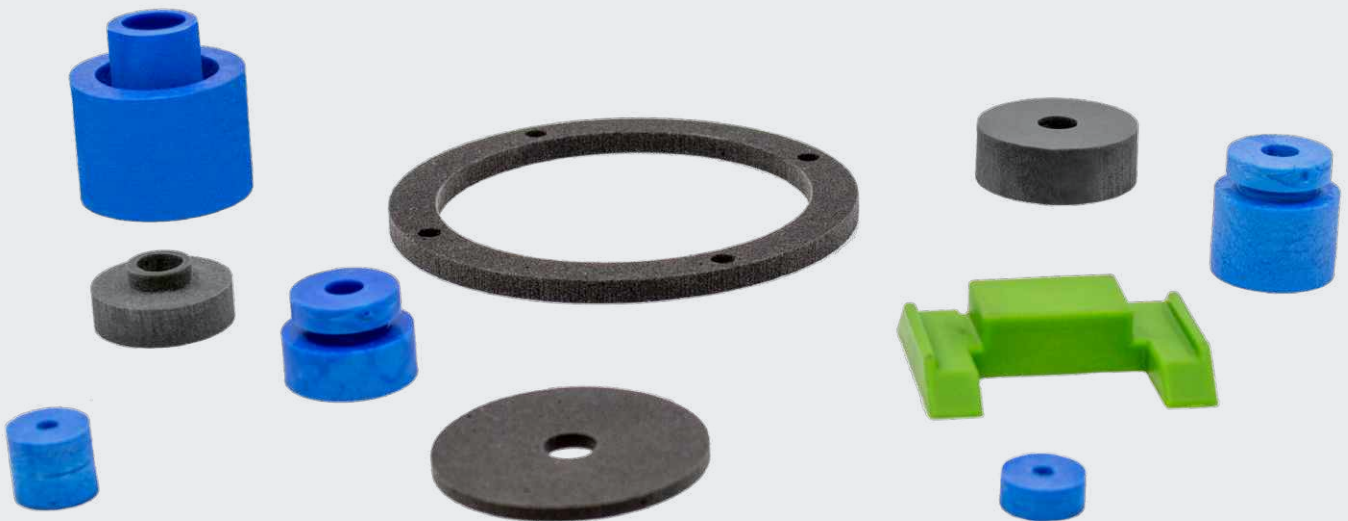

Chemical resistance

Sylocraft® has a very good resistance to acids and bases, aqueous solvents, fatty acids, glycols, aliphatic and organic cleaning solvents. As it is not chemical foamed there is no outgassing. No softeners are needed during the production process. Sylocraft® is resistant to ozone and UV. Due to its resilience, it is maintenance free and has a clearly extended lifetime compared to other elastomers types. Sylocraft® is 100 % recyclable.

Chemical resistance	Test conditions
10 % sulphuric acid (H ₂ SO ₄)	168 h / 23 °C
10 % caustic soda (NaOH)	168 h / 23 °C
50 % zinc chloride (ZnCl ₂)	168 h / 23 °C
Boiling water	168 h / 100 °C
Household Detergeant (30 g/l)	168 h / 95 °C
Potassium hydroxide (KOH)	168 h / 70 °C
ASTM N°1 oil	72 h / 100 °C
Isooctane (C ₈ H ₁₈)	168 h / 23 °C
Paraffin (C _n H _{2n+2})	168 h / 23 °C
Acetone (C ₃ H ₆ O)	168 h / 23 °C
Ethylene-glycol (C ₂ H ₆ O ₂)	168 h / 23 °C

Specific chemical resistance upon request.

Sylocraft® is a TPE (thermoplastic elastomer) with lots of advantages regarding the use in applications, which are close to humans:

- Smooth, silky surface haptics
- Countless possibilities in colours
- Odourless
- Nor organoleptic impact (food-contact quality available)
- Suppresses vibration and noise

Vibration isolation - individually created for you



Customer request



Technical feasibility -
geometry, pricing,
delivery times *



Offer to
customer *



Initial Samples production -
samples milled or cut
from blocks or made with
prototype mould *



Testing -
in application



Order



Mould design
and construction *



Prototypes *



Approval for
serial production

*support provided by Getzner Werkstoffe

Noise Reduction due to Customized Vibration Isolation

Machines, technical equipment, household appliances, sanitary equipment and pipes cause vibrations. Vibrations spread in housings, furnishing and buildings where they cause noise and other problems. Thus, an effective vibration isolation is needed. Sylocraft® is the best solution to get when you need efficient vibration isolation in small and complex geometries.

Getzner is an expert when it comes to vibration isolation - just like you are an expert in your business. Use our experience and our knowledge to get the best possible result for your product. Precise knowledge how to design an elastic bearing is crucial for vibrations isolation meeting highest demands (see "Efficient vibration isolation in detail").

Efficacy

To ensure an effective vibration isolation the ratio of static to dynamic stiffness needs to be as low as possible. In practical terms, it corresponds to a better noise and vibration reduction in the final application.



Your benefits

- Fitting vibration isolation resulting in more silent, compact products which are increasing the comfort of your customers
- No in-house competence in vibration isolation, tool design, tool management and testing needed on your side
- Time and costs savings due to custom-engineered design process

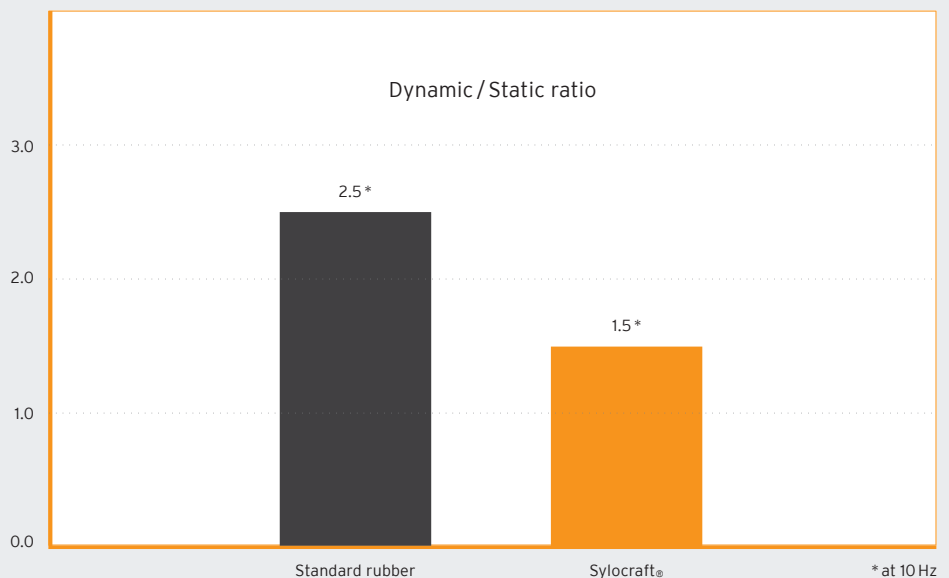

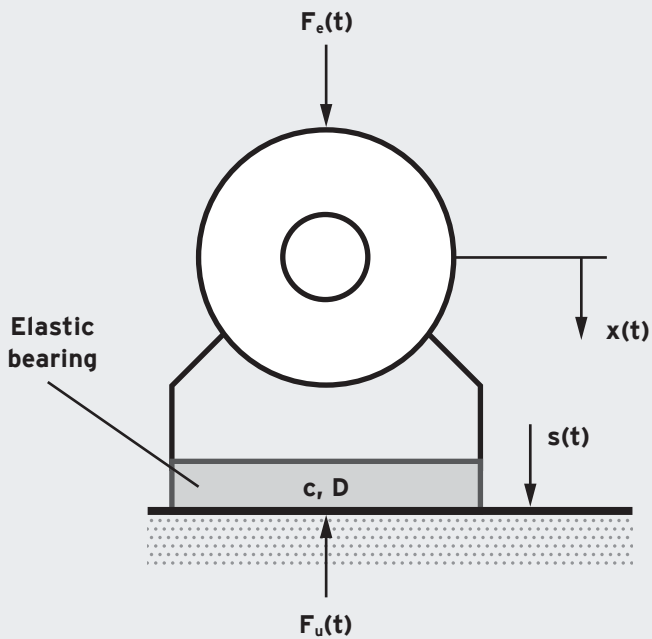

m [kg]	Machine mass
c [kN/mm]	Spring stiffness
D	Damping of the elastic bearing
$F_e(t)$	Exciting force
$x(t)$ [mm]M	Movement of the machine
$s(t)$ [mm]M	Force transmitted to the floor
$F_u(t)$ [N]F	Force transmitted into the foundation

Efficient vibration isolation in detail

The elastic installation elements and the mounted construction create, from a physical point of view, an oscillatory system. This is described using the single mass oscillator model and possesses a resonance or natural frequency. The characteristic vibration frequency is derived from the mass m of the system and the dynamic stiffness c of the elastic bearing.

$$f_0 = \frac{1}{2\pi} \cdot \sqrt{\frac{c}{m}}$$

The oscillatory system is excited by an external stimulus and starts to vibrate. The model refers to this as the exciting force. When assessing the isolating effect of a single mass oscillator, the frequency ratio η between the excitation

frequency of the external stimulus (f_e) and the natural frequency of the vibrating system (f_0) has to be considered.

$$\eta = \frac{f_e}{f_0}$$

An isolation effect only occurs in the frequency range $f_e/f_0 > \sqrt{2}$. So-called low frequency tuning occurs when the natural frequency f_0 of the system is around a factor of 1.41 lower than the lowest frequency f_e of the mechanical vibrations.

In the resonance range $f_e/f_0 < \sqrt{2}$ there is an amplification of the mechanical vibration in all cases, independent of the dampening.

Applications and References

Noise and vibrations have a huge impact on humans: Lower noise levels result in higher comfort. In addition, regulations demand lower noise levels for certain applications or the reduction of transmission of vibrations into the surrounding (SIA 181, DIN 4109). Sylocraft® helps you to minimize noise and vibration transfer of your products and meet the given requirements.

Proven efficacy in application

Tests with household-appliances showed significantly better noise levels when Sylocraft® was used as elastic decoupling.

Applications

- Refrigeration and air conditioning
- Machine bearings
- Floor systems
- Household appliances
- Transportation
- Sensors and electronic devices
- Sanitary
- Furniture and fittings
- Power tools
- Compressors
- Fastening systems

Noise levels in- and outside the house

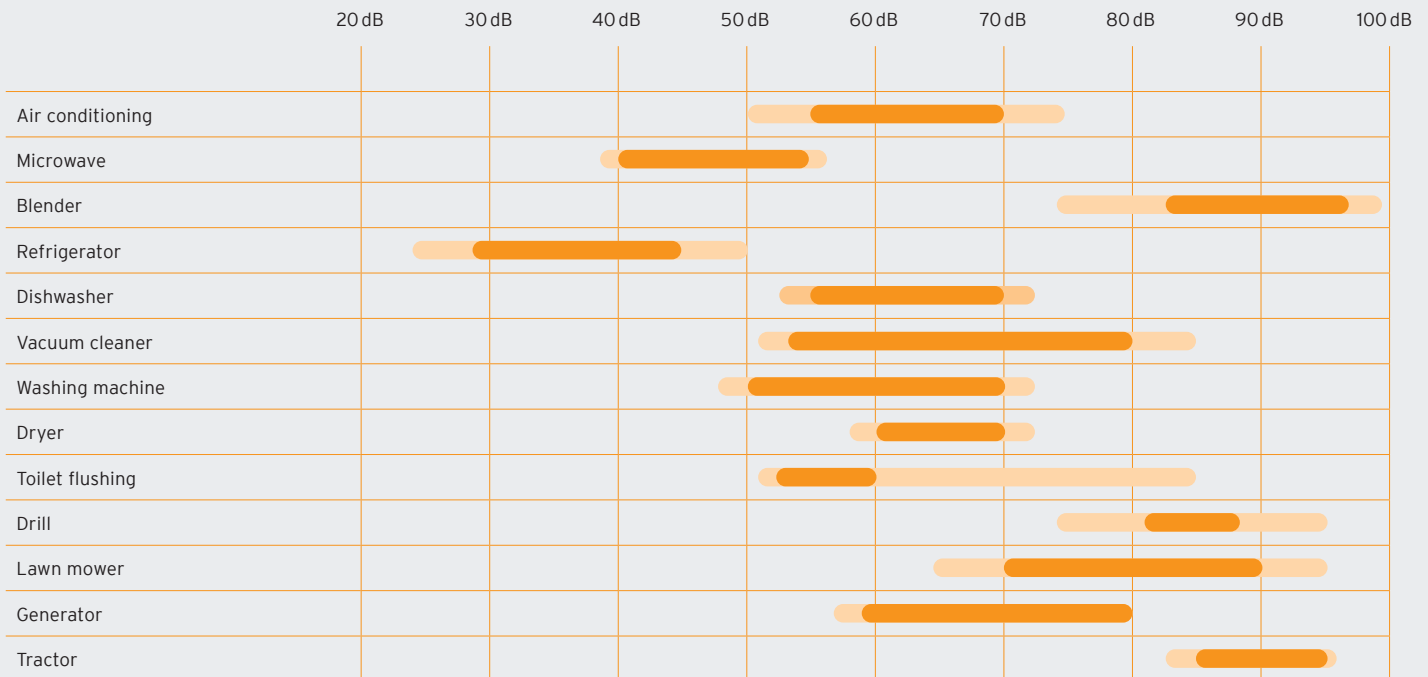

Proven efficacy in household applications



-40 %

Project

High-performance blenders spread unwanted vibrations from the base feet to the entire counter or work surface. Disruptive noises accompany these vibrations. The performance of Sylocraft® feet compared to standard rubber products was evaluated.

Results

On average, Sylocraft® feet reduced acceleration and thus vibration by approximately 40 %.



-5 dB

Project

Coffee machines with grinders generate vibrations in the kitchen area. These can lead to disturbing airborne noise. Sylocraft® elastic feet were installed on the outside of the machine instead of standard rubber products.

Results

In measurements an improvement of 5 dB was reached.



-10 dB

Project

Microwaves generate vibrations and airborne sound due to transformer and fan operation. Depending on the place of installation, vibration might be radiated into the environment as secondary airborne sound. Sylocraft® elastic feet were installed on the outside of the microwave instead of standard rubber products.

Results

Measurements show beginning with 60 Hz Sylocraft® works up to 10 dB better.

Getzner Werkstoffe GmbH

Herrenau 5
6706 Bürs
Austria
T +43-5552-201-0
F +43-5552-201-1899
info.buers@getzner.com

Getzner Werkstoffe GmbH

Am Borsigturm 11
13507 Berlin
Germany
T +49-30-405034-00
F +49-30-405034-35
info.berlin@getzner.com

Getzner Werkstoffe GmbH

Grünwalder Weg 32
82041 Oberhaching
Germany
T +49-89-693500-0
F +49-89-693500-11
info.munich@getzner.com

Getzner Spring Solutions GmbH

Gottlob-Grotz-Str. 1
74321 Bietigheim-Bissingen
Germany
T +49-7142-91753-0
F +49-7142-91753-50
info.stuttgart@getzner.com

Getzner France S.A.S.

Bâtiment Quadrille
19 Rue Jacqueline Auriol
69008 Lyon
France
T +33-4 72 62 00 16
info.lyon@getzner.com

Getzner France S.A.S.

19 Rue Hans List
78290 Croissy-sur-Seine
France
T +33 1 88 60 77 60

Getzner Vibration Solutions Pty Ltd

Unit 1 Number 2-22
Kirkham Road West,
Keysborough Victoria 3173
Australia

Getzner Werkstoffe GmbH

Middle East Regional Office
Abdul - Hameed Sharaf Str. 114
Rimawi Center - Shmeisani
P. O. Box 961294
Amman 11196, Jordan
T +9626-560-7341
F +9626-569-7352
info.amman@getzner.com

Getzner India Pvt. Ltd.

1st Floor, Kaivalya
24 Tejas Society, Kothrud
Pune 411038, India
T +91-20-25385195
F +91-20-25385199
info.pune@getzner.com

Nihon Getzner K.K.

6-8 Nihonbashi Odenma-cho
Chuo-ku, Tokyo
103-0011, Japan
T +81-3-6842-7072
F +81-3-6842-7062
info.tokyo@getzner.com

Getzner Materials (Beijing) Co., Ltd.

No. 905, Tower D, the Vantone Center
No. Jia 6, Chaowai Street, Chaoyang District
10020, Beijing, the P.R.C.
T +86-10-5907-1618
F +86-10-5907-1628
info.beijing@getzner.com

Getzner USA, Inc.

8720 Red Oak Boulevard, Suite 460
Charlotte, NC 28217, USA
T +1-704-966-2132
info.charlotte@getzner.com

www.getzner.com

